

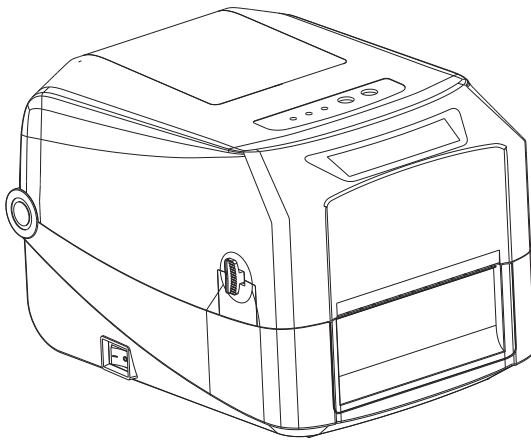

LP-1625

Thermal Transfer Barcode Printer

User Manual



Specification is subject of change without prior notice.

CONTENTS

1. The printer	02
1.1 Introduction	02
1.2 Product features.....	03
1.2.1 Standard equipment.....	03
1.2.2 Optional accessories.....	03
1.3 Specifications.....	03
1.4 Print specifications.....	04
1.5 Ribbon specifications.....	04
1.6 The paper size.....	04
2. Product introduction	05
2.1 Open and check	05
2.2 Printer components	06
2.2.1 Appearance	06
2.2.2 Internal	07
2.2.3 The bottom	07
3. Installation	08
3.1 Install the printer	08
3.2 Install the ribbon.....	08
3.3 Installation of paper	09
3.3.1 Installation of paper.....	09
4. LED indicator function	10
4.1 LED indicator	10
4.1.1 Thermal printing	10
4.2.2 Thermal transfer printing	10
4.2 Button Function	11
4.3 Start function	11
5. Troubleshooting	13
5.1 Common problem	13
6. Maintenance	15
6. 1. Printer Cleaning	15

1.The printer

1.1 Introduction

Thanks for choosing LP-1625 series direct thermal and thermal transfer label printer.h

This series printer is built with 2 sets of gear to drive motor, with capability of handling 300 meters long ribbon and large label roll. Printer inner volume is fit for 5" OD (Outer Diameter) paper roll, if using external paper holder, you can install 8.4"OD industrial grade label roll.

This printer is designed for real-time and batch label printing, with standard serial, parallel, USB and Ethernet connection port. Direct thermal printing and thermal transfer printing modes are all in one printer body, so you can choose various kinds of printing materials, for example: thermal paper, plain paper, coated paper, silver paper, plastic paper etc.

Common 1D barcode and 2D barcode fonts are built inside printer, also it support 4 direction printing, characters can be enlarged from 1 to 10 times. Besides, it supports 5 different size bitmap fonts, OCR-A and OCR-B fonts, together with 203dpi higher print resolution, this series printer are your best choice among the same class.

Declaration: This is a class A product, fit for Non Tropic regions installation. This product may cause radio interference in life environment, users may need to take adequate preven-five measures.

◆ Application Field

- ◆ Manufacturing & Warehousing logistic industry
 - Product labeling and marking
 - Warehouse management label
 - Category marking label
 - Operation instruction marking label
 - Distributing instruction marking label
- ◆ Healthcare
 - Patients marking
 - Medicine marking
 - Specimen marking
- ◆ Parcel Post
 - Mailing label
- ◆ Office & Studio
- ◆ Retail
 - Price Label marking
 - Product item marking
 - Jewelry product marking

1.2 Product features

Standard equipment

Product standard	203DPI	
Ribbon printing	○	
Thermal printing	○	
ABS plastic housing	○	
Gap sensor	○	
Ribbon sensor	○	
The print head open sensor	○	
USB 2.0(full speed)Communication interface	○	
2 MB SDRAM Memory	○	
2 MB FLASH Memory	○	
The paper key and LED indicating lamp	○	
Built in 8 dot matrix font English number	○	
The character and the bar code can be printed in four directions of rotation (0,90,180,270) degree.	○	
Built in simplified Chinese, traditional and Korean font for programming.	○	
Can print text, bar code, pictures		
Support bar code		Support picture format
1D Barcode	2D Barcode	○
Code 39 Code 93,ITF, EAN 128, Code 128 subsets A,B,C, Codabar, EAN-8,EAN-13, UPC-A,UPC-E, EAN and UPC 2(5) digits add-on,MSI,MSIC, PLESSEY,CPOST, ITF 14,EAN 14	QR code BMP, PCX	

1.3 Specifications

Specifications	
Printer size	278(W)X210(D)X180(H)
Printer weight	2.09KG
Power Supply	The built-in voltage automatic switching power supply Input: AC 100-240V Output: DC 24V 2A
Support picture format	Work environment5~45°C (41~104°F), 25~85% Dampness Storage environment±10~50°C (-10~140°F), 10~90% Dampness

1.4 Print specifications

Model	LP-1625
Emulation	341625001 with cutter, TSPL emulation 341625002 without cutter, TSPL emulation 341625003 with cutter, ZPL emulation 341625004 without cutter, ZPL emulation
The print head	203dots/inch(8dots/mm)
Print mode	Ribbon / thermal
Dot size(the size) (width X length)	0.125X0.125mm (1 mm = 8 dots)
Print speed (inches per second)	2~6inch/s
Maximum print width	108mm(4.25")
Maximum print length	2286 mm(90")
Pulse excitation	1X10 ⁸ pulses
Heat sensitive piece (wear)	50km

1.5 Ribbon specifications

Ribbon diameter	Max.67 mm
The ribbon length	300 m
The ribbon axis size	1 inch (25.4 mm)
The ribbon width	Max. 110mm
	Min. 30 mm
Ribbon winding form	The outer coil type

1.6 The paper size

Model	LP-1625
The maximum capacity of internal paper roll diameter	127 mm(5")OD
Paper type	Continuous paper, gap of paper, paper folding, punched paper
The paper winding form	Print out of plane roll / print surface involute
The width of the paper (tag + bottom paper)	Max. 120mm(4.72")
	Min. 20mm(0.78")
The thickness of the paper (tag + bottom paper)	Max. 0.254mm(10mil)
	Min. 0.06mm(2.36mil)
Roll axis size	25.4mm~38mm(1"~1.5")
Label length	10mm~2286mm(0.39"~90")
	Note:If you use the tag length less than 25.4mm (1"), recommend the use of a perforated line in the gap on the label paper so the tear.
The paper height gap spacing	Min.2 mm(0.09")

2. Product introduction

2.1 Open and check

This series printer is with special package to prevent damage in transportation. If there is any unexpected damage occurred, please put in clean and stable surface and carefully open the package to check, inform local distributor with damage details, and keep packing materials well in case you need to mail the printer.

Packing list:

- ◆ One Label printer
- ◆ CD (Driver, Nice label software, User Manual)
- ◆ Power Adapter
- ◆ Power Cord
- ◆ USB cable (Parallel cable, serial cable optional)
- ◆ Ribbon roller& Ribbon
- ◆ Label roller & Label paper

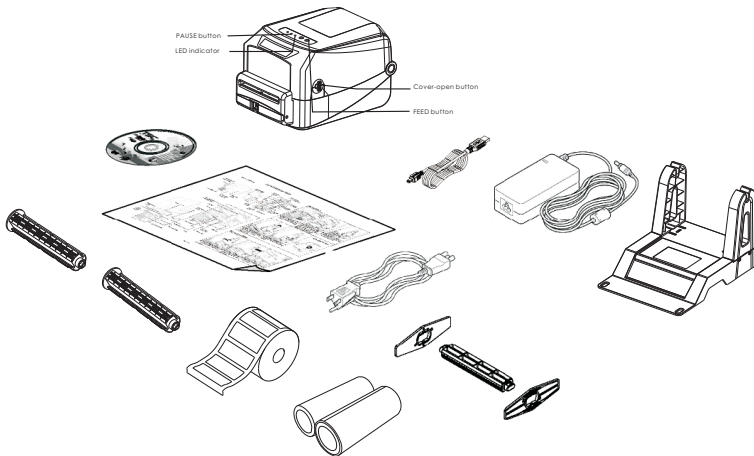

<Picture 1>

Please pack equipment and materials needed for safekeeping printer for subsequent handling; if the above items, any lost or missing, please Customer Service Department of your purchase contact.

2.2 Printer components

2.2.1 Appearance

LED lights indicate:

- ★ ON LINE electric lamp
- ★ ERROR error lamp
- ★ RIBBON ribbon status light

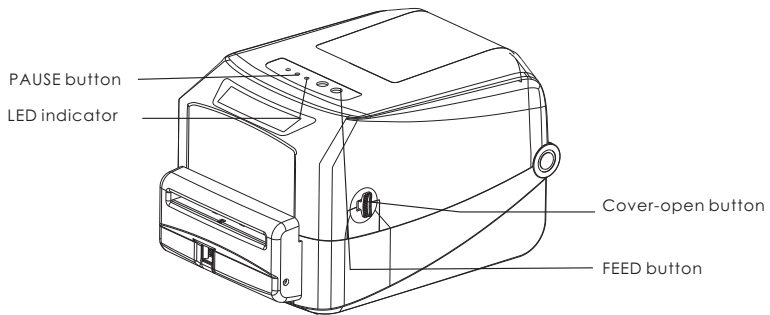

2.2.2 Internal

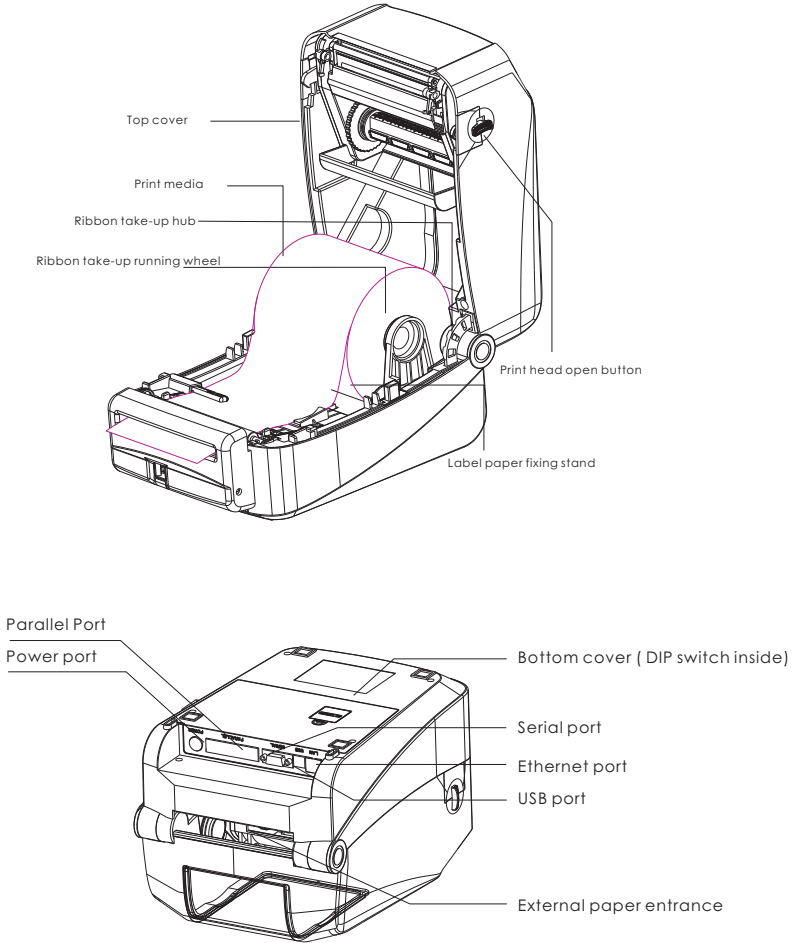

Note: Picture showing printer port is for LP-1625.

3. Installation

3.1 Install the printer

1. Please put the printer on the stable surface.
2. Make sure printer power is turned off, please do not plug the power cable when the printer power is turned on.
3. Connect serial or USB or Parallel or Ethernet cable to printer and PC.
4. Connect power plug to power supply socket.

Be careful:

- ※ Please turn off the power switch the printer in the power socket, power line is inserted into the printer.
- ※ Transmission interface in the picture will vary depending on your printer purchased aircraft type, the actual transmission interface, please refer to the corresponding product specifications

3.2 Ribbon installation

Ribbon loading

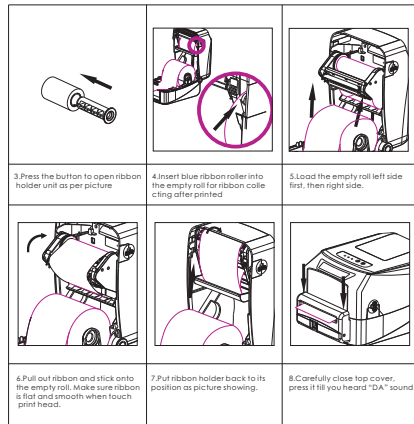

- Ribbon installation diagram

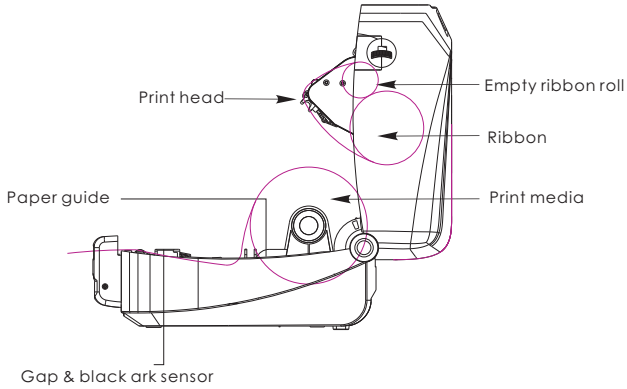

3.3 Installation of paper

3.3.1 Installation of paper

Print media Loading

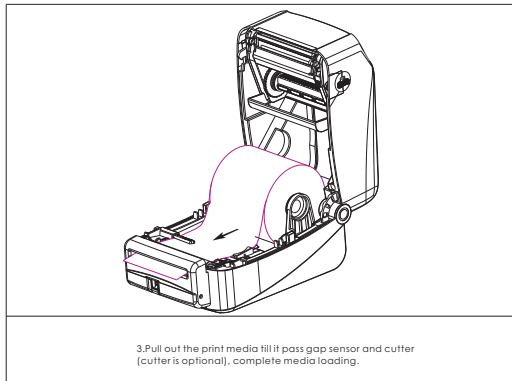
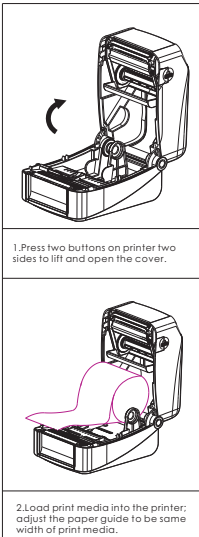

- Paper installation diagram

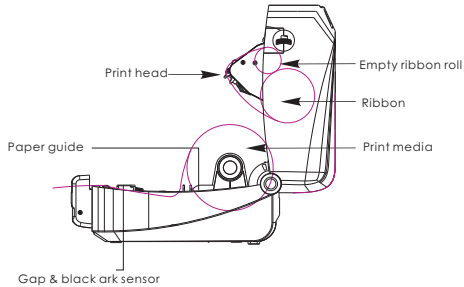

4. LED Indicator and Function

There're two buttons and three LED indicators, many functions can be realized through using different button, indicator and power on/off switch.

4.1 LED indicator

4.1.1 Direct thermal printing method

LED Indicator status	Descriptions
Power indicator is on ,Error indicator is off	Printer is powered on and in normal printing status
Power indicator flashes every 640ms, Error indicator is off	Printer is paused
Power indicator is off, Error indicator goes on for 80ms, then goes off for 160ms, printer start beeping.※	Printer cover is opened
Power indicator is off, Error indicator goes on for 500ms, then goes off for 6s	Label gap detection error
Power indicator is off, Error indicator flashes every 160ms, after two times flashing, Error indicator goes off for 320ms, printer start beeping. ※	Paper out
Power indicator is off, Error indicator flashes every 160ms, after three times flashing, Error indicator goes off for 320ms, printer start beeping. ※	Black mark detection error
Error indicator flashes every 160ms.	Printer overheated protection mode is activated. After 1 minute, the printer CPU will check print head temperature again. When temperature return normal, printer will work normally.

※ Beeper function can be enabled through setting DIP switch.

4.1.2 Thermal transfer printing

LED Indicator status	Description
Ribbon indicator is on	Ribbon is installed successfully
Ribbon indicator flashes every 300ms, beeper sounds every 2.4s ※	Ribbon improperly installed: no ribbon, or ribbon end, or ribbon broken

※ Beeper function can be enabled through setting DIP switch.

4.2 Button Function

1. Feed

When the printer is ready (LED blue fixed), click the button, label paper into the front end of a paper label.

2. Print job timeout

The printer in the print, click the PAUSE button to print suspended. At this time power indicator is blue flashing. Just click the button, the print job resume normal.

4.3 Start function

The printer has six kinds of power function can be used to set or test the printer hardware. In the boot and press the button with lamp signal release key can start these functions.

Six Power-up Functions:

Function	Descriptions
Self-test page	<p>A. Turn off the printer. B. Make sure the paper roll is installed correctly and the printer top cover is closed. C. Press and hold FEED button and turn on the printer. Self-test page will be printed, then release FEED button. You can use this function to check if printing function is normal or not.</p>
Print DIP Switch page	<p>A. Turn off the printer. B. Make sure the paper roll is installed correctly and the printer top cover is closed. C. Press and hold PAUSE button and turn on the printer. When paper feed and then release PAUSE button, DIP switch page will be printed out.</p>
Debugging Mode	<p>A. Turn off the printer. B. Make sure the paper roll is installed correctly and printer top cover is closed. C. Press and hold PAUSE and FEED button, and turn on the printer. When Power indicator (blue) and Error indicator (red) are on at the same time, release PAUSE and FEED button, printer goes to Debugging Mode, and you will find below page printed out:</p> <div style="border: 1px solid black; padding: 10px; margin: 10px 0;"> <pre>***** * NOW IN DUMP MODE * *****</pre> </div> <p>All label data received in this mode will be printed by machine code. Right side is ASCII character strings, left side are hexadecimal value of ASCII character strings. This function is for user or engineer to debug the program. If you turn off printer and then turn on, printer will go back to normal printing mode.</p>

Skip AUTO.BAS program	<p>User can use TSPL2 command to save a code auto-running file (AUTO . BAS) into flash. When turn on printer, printer will run the program automatically.</p> <p>If you want to skip AUTO . BAS program on power-up, then follow below steps:</p> <p>Press and hold PAUSE and FEED button, then turn on the printer. When Power indicator (blue) is off and Error indicator (red) is on, release PAUSE and FEED button, printer will skip running AUTO . BAS program, and then Power indicator will be on.</p>
Printer Initialization	<p>A. Turn off the printer.</p> <p>B. Press and hold PAUSE and FEED button, then turn on the printer. When Power indicator (blue) is on and Error indicator (red) is off, release PAUSE and FEED button, all data in printer DRAM will be cleared and printer setting will be restored to factory default setting. Then power indicator will be on and printer goes to ready status.</p> <p>* Factory default settings do not include ribbon setting.</p>
Ribbon Detection	<p>When printer power turn on, or it is in thermal transfer printing mode, printer will automatically detect ribbon status, to check if ribbon installed, or ribbon end, or work normally. After ribbon detecting, printer will be set to thermal transfer printing mode or direct thermal printing mode. If no ribbon, system will go to direct thermal printing mode and close ribbon rolling motor function.</p>

The printer configuration after the initialization will revert to the default values are as follows:

Parameter	Default setting
Speed	4inch/sec (101.6mm/sec), 203dpi
Density	10
Gap	0mm
Direction	Printing content are placed on page from top to bottom
Reference	Top left corner from printing direction
SHIFT	0
OFFSET	0
SET TEAR	ON
SET HEAD(Cover open detect)	ON
Set PRINTKEY	OFF
SET REPRINT	OFF
SET KEY1(FEED)	ON
SET KEY2(PAUSE)	ON
CLEAR RAM	CLEAR
CLEAR FLASH	NOT CLEAR

5. Troubleshooting

5.1 Common problem

Below the table of contents is generally the common problems and solutions; if you have been in our proposed methods of eliminating the fault, and the printer is not normal operation, so check with your purchase customer service department, so as to get more help.

Problems	Possible Reasons	Solution and Suggestion
Power indicator not "ON"	Plug to AC outlet and plug to printer not well connected	Check power connector and AC outlet if plugs are correctly connected
	Printer power not turned on	Turn on power switch
	Print head not well closed	Close print head by pressing whole print head mechanism (or 2 arrow locations)
	Ribbon end	Change new ribbon
	Ribbon improperly installed	Refer to Ribbon Installation steps in User Manual to re-install ribbon
	Label paper end	Change new label paper
	Label paper improperly installed	Refer to Paper Installation steps in User Manual to re-install paper
	Gap sensor detection error	Adjust paper specification and print again
	Label paper jammed inside printer	Clear jammed paper
Not printing	Serial cable improperly connected	<ol style="list-style-type: none"> 1. Check if Pin configuration in cable two sides are matching each other; 2. Check if baud rate setting on PC and printer are the same, If in TPSL comma -nd mode, We suggest 9600, n, 8, 1 to ensure higher reliability. 3. Change a new cable.
	Ethernet cable improperly connected	<ol style="list-style-type: none"> 1. Check if RJ-45 green/orange LED indicator is on. When printer receive and process printing data, LED will be orange color; 2. Check if printer IP is assigned in DHCP mode. 3. Check if fixed IP address is correctly set in printer property. Wait for some minutes to make sure printer is connect -ed server and printing a selftest page to confirm printer IP address. 4. Change a new ethernet cable.
	USB cable improperly connected	Check if USB cable connected well or change a new cable
	Ribbon non standard	Check if ribbon model and specification

Not printing	Ribbon printing side wrong installed	Check and re-install ribbon to make sure printing side touch label paper
	Print head not clean	Clean print head and print again
	Print density setting wrong	Suggest density set to be 7
	Print head cable not well connected	Re-connect print head cable
	Step Motor cable not well connected	Re-connect step motor cable
	Command setting wrong	Check if there is PRINT command at the end of printing file; or if there is CRLF command at the end of every line.
Not good printing quality	Ribbon and label improperly installed	Re-install ribbon and/or label
	Too much dust or adhesive on print head	Clean print head and print again
	Print head damaged	Take selftest page to check if printing are completely to confirm if necessary to change new print head
Data miss printing in one or two sides	Label paper size wrong setting	Check if label size set correctly and same as your label paper
Ribbon wrinkle	Print head unbalanced stress; ribbon & label improperly installed; Label feeding not smoothly	Reset the label print density and adjust paper width fixing stand to fit your label paper size.
Printing not stable	Printer in HEX Dump mode or RS-232 setting wrong	Restart your printer and leave Dump Mode or reset RS-232 PARAMETER

6. Maintenance

6.1. Printer Cleaning

To ensure the printing quality, please proceed this maintenance section to keep your printer in good conditions and extend its life as well.

Please use one of following material to clean the printer.

- ★ Cotton swab
- ★ Lint-free cloth
- ★ Vacuum / Blower brush
- ★ 100% ethanol

2.The cleaning process is described as following:

Parts to be cleaned	Step	Recommend cleaning frequency
Print head	<ol style="list-style-type: none"> 1. Turn off the printer. 2. Allow the print head to cool for at least one minute. 3. Use a cotton swab and 100% ethanol to clean the print head surface. 	When change new label paper
Rubber roller	<ol style="list-style-type: none"> 1. Turn off the printer. 2. Rotate the platen roller and use a cotton swab to clean with 100% ethanol. 	When Change new label paper
Paper tear bar	Use a cotton swab and 100% ethanol to clean.	When necessary.
Sensor	Use air brush or vacuum to clean dust of sensor.	Monthly.
Inner side of printer	Use air brush or vacuum to clean the dust.	When necessary.

Note:

- ※ Always turn off the printer power before cleaning the printer.
- ※ Do not touch print head by figure.
- ※ Please use 100% ethanol, Do not use medical alcohol to avoid damage to print head.

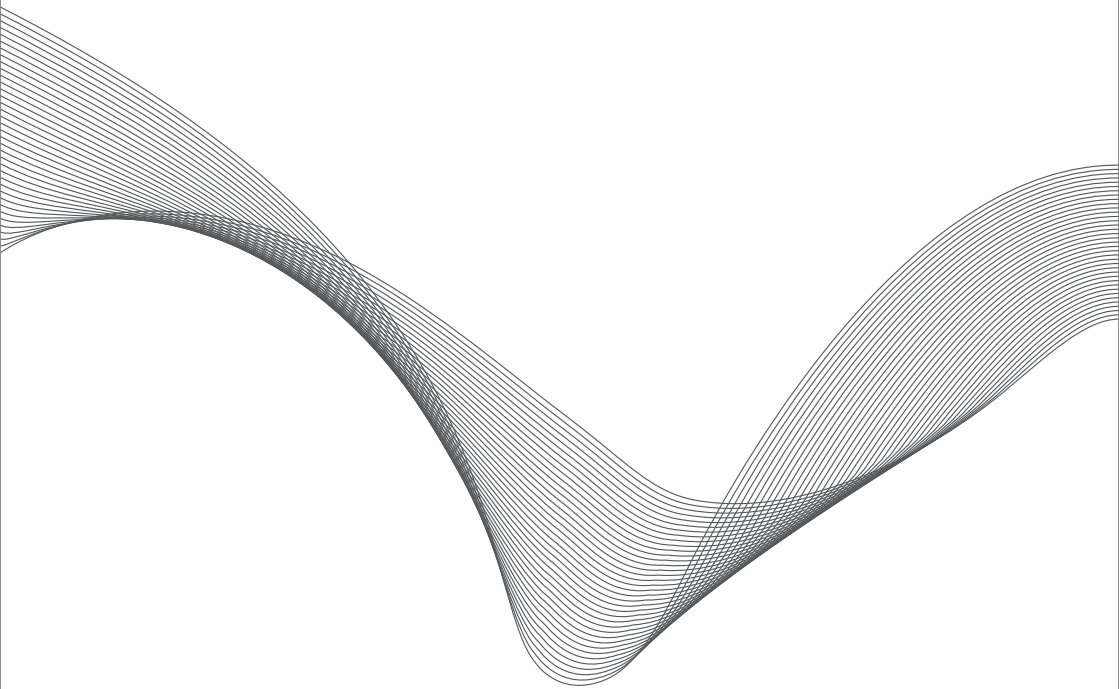

Partner Tech Europe GmbH

Add:Fasanenweg 25, 22145 Hamburg